

A Comparative Study to Determine the Dimensional Accuracy of Different Impression Materials

S. Chandrakala¹, Ganesh Ramesh², Sanjna Nayar³

¹Post graduate student, ²Professor, ³Professor and Head, Department of Prosthodontics, Sree Balaji Dental College and Hospital, Chennai

Abstract

Background: The accuracy and dimensional stability of dental impression materials are of great importance, since a material which shrinks, expands or warps during or after removal from the mouth will result in an inaccurate model and potentially, a badly-fitting prosthesis. The purpose of this study was to evaluate the dimensional accuracy of the impression materials immediately after setting and also to determine the change in dimensional accuracy after 24 hours.

Materials and Method: Four impression materials were selected among which two were hydrocolloids and two were elastomers. Fifteen samples of each were experimentally tested immediately and 24 hours after sample preparation. Data obtained were subjected to t-test and analysis of variance for statistical comparisons at a 5% level of significance.

Results: The linear difference in measurements were recorded immediately and 24 hours after setting. The changes in dimensional accuracy with respect to time were statistically analysed and it showed no statistically significant difference between the materials both immediately and after 24 hours.

Conclusion: Within the limitations of the study,

It can be concluded that there were similar results for dimensional accuracy for all the materials tested immediately after sample preparation but there was considerable disparity with the same tested after 24 hrs for hydrocolloids and not much of difference was noted for elastomers.

Keywords: Dimensional accuracy, Impression materials, elastomers, hydrocolloids

Introduction

Dental impression materials are used to generate a negative replica of the dental hard and soft tissues. The accuracy and dimensional stability of dental impression materials are of great importance, since a material which shrinks, expands or warps during or after removal from the mouth will result in an inaccurate model and potentially, a badly-fitting prosthesis¹.

Accuracy of impression is dependent on the dimensional stability of impression material and also influenced by a number of factors such as impression technique, impression tray, and properties of the impression materials.

Clinically impression materials can be divided into two large groups²:

- 1) Hydrocolloid impression materials that include agar-agar and alginate impression materials;
- 2) Synthetic elastomeric impression materials that include polysulfide, condensation silicone, addition silicone, and polyether

Obtaining an accurate cast of a dental arch is an important step in the success of various dental treatments. Because of time constraints pouring of impression by dentists themselves is on the decline, as they prefer to send impressions to dental laboratories for making cast¹. Thus, a considerable delay is caused in pouring the model, after removal of the impression from the mouth;

which is one of the reasons for causing dimensional changes in the impression, thereby threatening the dimensional accuracy of the prosthesis^{1,2}.

Dimensional accuracy of impression materials are evaluated using the mould prepared by ADA specification no.19 that possesses vertical and horizontal lines that intersect each other at fixed points providing a standard distance value. The distance between the fixed points was evaluated at different time intervals to determine the dimensional accuracy. Any deviation from the fixed value indicates the change in dimensional accuracy.

This study has presented the comparison of dimensional accuracy of different commonly used impression materials at different time intervals.

Materials and Method

DIE PREPARATION

For the present study, a stainless-steel die was prepared according to the ADA specification No.19. According to ADA specification 19, each die consisted of a cylindrical stainless block of 38mm diameter, with a 30mm diameter step on its superior surface. The die was scored with 3 horizontal lines and 2 vertical lines on the top of the impression surface. The horizontal lines were marked as X, Y, Z, and vertical lines were marked as CD and C'D' for ease in making measurements.

The distance between two horizontal lines is 2.5 mm and between two vertical lines is 25 mm. The die was subjected to Nd-YAG Laser treatment and 3 horizontal and 2 vertical lines were scribed, with a width of 0.016 mm on top of 30 mm diameter surface. The die has a highly polished surface. The die also contains a ring that surrounds the periphery of it, which serves as a tray or as a container for the impression material.

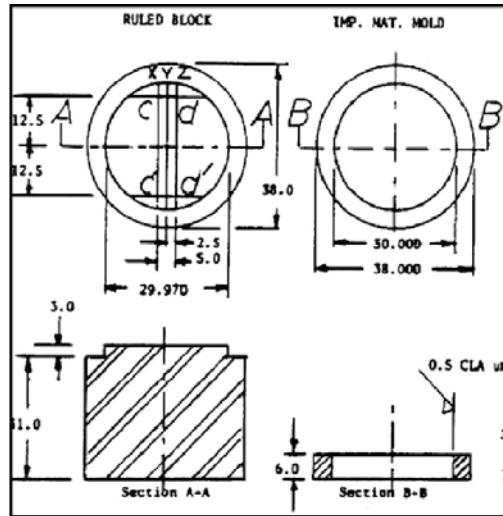

Figure 1 : ADA Specification no.19



Figure 2 : Stainless steel die

SAMPLE PREPARATION

Each material was manipulated as mentioned above and evenly spread over the die and a glass slab is placed over the impression material for an even polished surface. The whole assembly was kept undisturbed for the setting time suggested by the manufacturer.

After the adequate setting time, the material was separated from the die. Thus prepared specimens were measuring 30 mm in diameter 3 mm in thickness and had lines X, Y, Z, CD, C'D' lines on it. Similarly, all 60 void-free samples were obtained. In between the time of observation, the samples were stored at normal room temperature.

EVALUATION OF DIMENSIONAL ACCURACY

The sample was placed over the vertical profile projector. The distance between the lines CD and C'D' intersecting with line Y was measured using a

vertical profile projector. The readings were recorded immediately and 24 hours after sample preparation.

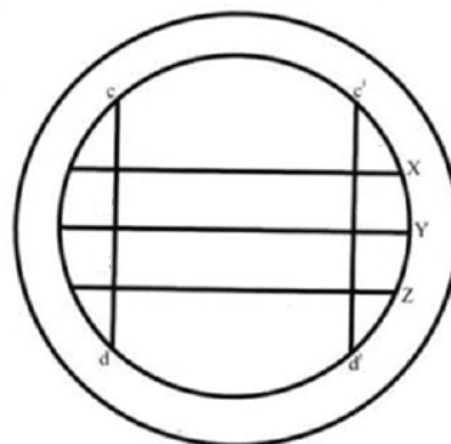

Figure 3 : Horizontal X, Y, Z, and vertical CD and C'D' lines

C'D' lines

SPECIFICATIONS OF THE PROFILE PROJECTOR

Parameters	Description
Screen diameter (mm)	300 round glass with cross lines
Rotating range	0 to 360 degrees
Rotating angle range	1 minute digital encoder
Magnification standard	Telecentric optics :10x
Standard work table	290mm X 175mm
Measuring range X / Y & Z axis	150mm X 100mm
Operation	Manual X, Y & Z axis
Linear scale	Glass scale res 0.001mm
Surface illumination accuracy	< 0.05 percentage on screen
Profile illumination accuracy	< 0.075 percentage on screen

Parameters	Description
Surface illumination	150w, 24v with heat filter and fan-cooled systems
Profile illumination	100w, 24v with heat filter and fan-cooled systems
Surface illumination systems	Dual-beam split light source with control adjustment
Workload capacity	4 to 5 kg



Figure 4 : Determining dimensional accuracy of impression material using vertical profile projector

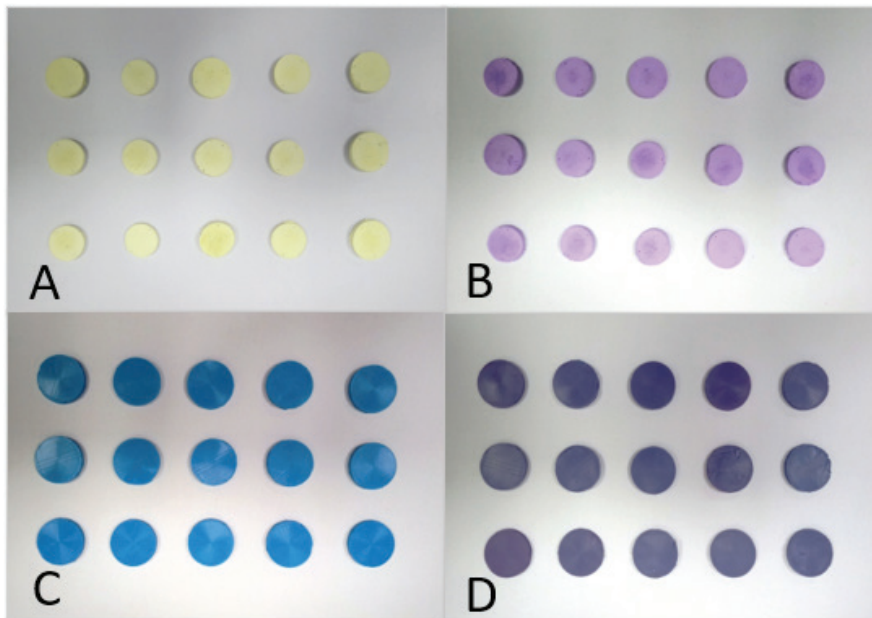

Figure 5 : samples (15 Nos) dimensional accuracy

Statistical Analysis

All statistical tests are done with a P-value considered as 0.05 with 95% probability accuracy level. If the resultant P-value of the tests is less than 0.05 H_0 is accepted and if it is greater than 0.05 H_1 is accepted.

The ANOVA and t-test results comparing the immediate results after sample preparation of all four impression materials showed that there is no statistically significant difference between the materials but with the time difference of about 24 hours there is statistically significant difference between the materials.

The dimensional accuracy values taken immediately after sample preparation showed that alginate is the least accurate while cream alginate had better accuracy more equivalent to the elastomers and vinyl polysiloxane had the highest range of accuracy among the others.

The dimensional accuracy values recorded 24 hours after sample preparation showed that alginate and cream alginate had an unacceptable change in accuracy while elastomers showed better accuracy and had dimensional stability even after 24 hours. The dimensional accuracy changes evaluated showed that hydrocolloids showed more changes while elastomers had negligible changes only

TABLES: DIMENSIONAL ACCURACY - IMMEDIATE

Dimension (in mm)	Alginate	Cream Alginate	Poly Ether	Vinyl Poly Siloxane
Immediate	24.14	24.63	24.95	24.99

DIMENSIONAL ACCURACY - AFTER 24 HOURS

Dimension (in mm)	Alginate	Cream Alginate	Poly Ether	Vinyl Poly Siloxane
After 24 hours	19.83	19.66	24.88	24.89

DIMENSIONAL ACCURACY COMPARISON

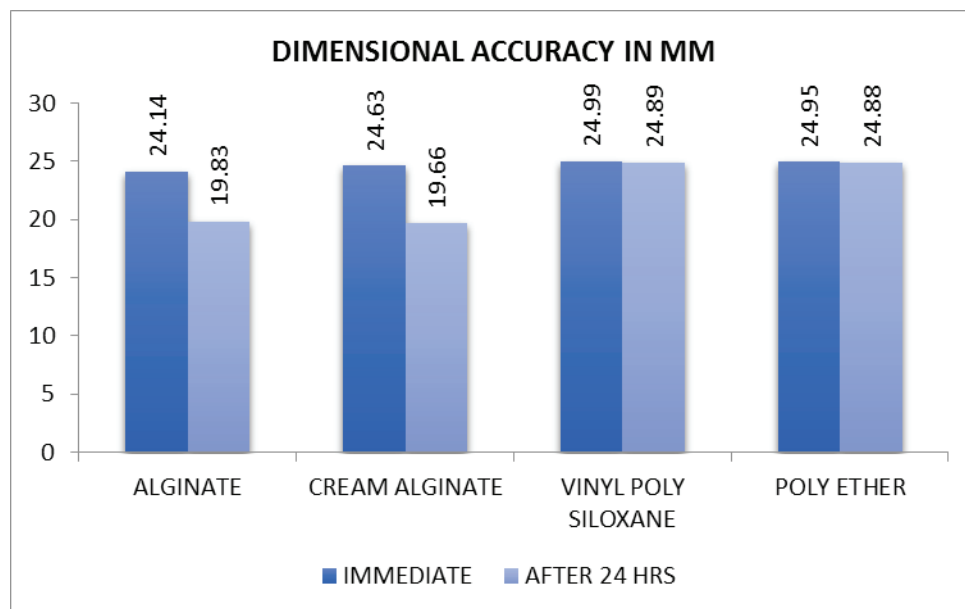

Figure 6 : Comparing Dimensional accuracy changes

of impression materials

Discussion

All the recently introduced material claims dimensional accuracy because of improved techniques of production, sophisticated handling of materials, operating environment, etc and they claim superiority of material properties over the existing materials.

Lack of evidence-based basic scientific knowledge on recently introduced materials created the necessity for basic in-vitro studies in regard to material properties. With the mushrooming of dental manufacturers, their claims & scarce literature of newer emerging material properties created the mandatory necessity for material comparison with existing old material and its concepts. With the ever-changing concepts, it's very difficult for any dentist to properly select material without evidence-based literature.

The study was planned to compare the properties of materials available in the market so that it will provide a fair idea about any improvements in relation to its accuracy and wettability. Therefore, in this study new material named as cream alginate that claims surface reproduction up to 5µm was used. The dimensional accuracy of this newly introduced cream alginate was compared with the commercially available alginate and the dimensional accuracy of polyvinyl siloxane and polyether was also compared among the elastomers. Dimensional accuracy of the cream alginate was much better compared to the normal alginate and it showed accuracy more or less equivalent to the elastomers.

Impression materials should have the ability to reproduce a true value and they should be dimensionally stable across time. But accuracy depends on the evaporation of water and syneresis^{1,2} in case of hydrocolloids. Dimensional change of impression material is multifactorial and material specific. Kulkarni et al. stated that dimensional stability of the impression material showed the greatest discrepancy from the standard model which was 0.005 inches and extended-pour alginate was 0.003 inches (approximately 75 µm) on the day one of pour³. Generating the casts from the conventional alginate sooner is beneficial⁴.

The amount of expansion or shrinkage when evaluated in a study conducted by Manisha et al., showed that the casts obtained by pouring alginate impressions immediately showed accurate results even though insignificant difference was observed when impression was stored at varying degrees of temperature for 20 minutes, but the values obtained by storing of alginate impressions for 20 minutes at 30°C were found to be nearly accurate than the values obtained by storing of impression at 40°C³.

A net contraction in the material follows the formation of the insoluble gel and the contraction may continue even if the impression is immersed in a liquid. During shrinkage, if impression material is bounded tightly with trays then the material will be pulled toward the tray which causes an increase in tooth and arch widths. During imbibition, it will distort by swelling. The shrinkage of material that took place towards the bulk of the material is in accordance with the study by Wadhwa SS et al.,⁵.

In this study also we have evaluated the dimensional accuracy and wettability of impression materials 24 hrs after sample preparation which showed wide variation from the accuracy obtained immediately after sample preparation. Both elastomers and hydrocolloids showed similar results for dimensional accuracy immediately after sample preparation and cream alginate showed much closer accuracy with that of the elastomers. Therefore if the cast is poured immediately after impression making, cream alginate can also be used as a choice of impression material for tooth preparation also.

Conclusion

Within the limitations of the study,

It can be concluded that there were similar results for dimensional accuracy for all the materials tested immediately after sample preparation but there was considerable disparity with the same tested after 24 hrs for hydrocolloids and not much of difference was noted for elastomers.

When casts are poured immediately after impression making all the four materials would be able to provide better accuracy. Newly introduced cream alginate showed better dimensional accuracy equivalent to the

elastomers and can be considered for usage.

Ethical Clearance - Institutional Ethics Committee, Sree Balaji Dental College and Hospital, Committee registered with DCGI. (Registration no: SBDCH/IEC/04/2019/23)

Source of Funding – Nil

Conflict of Interest – Nil

References

1. Sedda M, Casarotto A, Raustia A, Borracchini A. Effect of storage time on the accuracy of casts made from different irreversible hydrocolloids. *J Contemp Dent Pract.* 2008;9(4):1–12.
2. Imbery TA, Nehring J, Janus C, Moon PC. Accuracy and dimensional stability of extended-pour and conventional alginate impression materials. *J Am Dent Assoc [Internet].* 2010;141(1):32–9. Available from: <http://dx.doi.org/10.14219/jada.archive.2010.0018>
3. Kulkarni MM, Thombare RU. Dimensional changes of alginate dental impression materials-an invitro study. *J Clin Diagnostic Res.* 2015;9(8):ZC98–102.
4. Lewinstein I, Craig RG. Accuracy of impression materials measured with a vertical height gauge. *J Oral Rehabil [Internet].* 1990 Jul [cited 2019 Oct 17];17(4):303–10. Available from: <http://www.ncbi.nlm.nih.gov/pubmed/2213324>
5. Wadhwa S, Mehta R, Duggal N, Vasudeva K. The effect of pouring time on the dimensional accuracy of casts made from different irreversible hydrocolloid impression materials. *Contemp Clin Dent.* 2013;4(3):313.